



Horizontal Gear-Driven Slicers
Model MS-IT-0300-H, 0330-H, 0350-PM
Items 13655, 13656, 13657
Instruction Manual



Revised - 05/18/2023



Toll Free: 1-800-465-0234
Fax: 905-607-0234
Email: service@omcan.com
www.omcan.com



Table of Contents

Model MS-IT-0300-H / Model MS-IT-0330-H / Model MS-IT-0350-PM

Section	Page
General Information -----	3 - 4
Safety and Warranty -----	4 - 5
Technical Specifications -----	6
Installation -----	6 - 7
Operation -----	7
Maintenance -----	7 - 9
Illustrated Drawings -----	10
Parts Breakdown -----	11 - 22
Electrical Schematics -----	23
Notes -----	24 - 26
Warranty Registration -----	27



General Information

Omcan Manufacturing and Distributing Company Inc., Food Machinery of America, Inc. dba Omcan and Omcan Inc. are not responsible for any harm or injury caused due to any person's improper or negligent use of this equipment. The product shall only be operated by someone over the age of 18, of sound mind, and not under the influence of any drugs or alcohol, who has been trained in the correct operation of this machine, and is wearing authorized, proper safety clothing. Any modification to the machine voids any warranty, and may cause harm to individuals using the machine or in the vicinity of the machine while in operation.

CHECK PACKAGE UPON ARRIVAL

Upon receipt of an Omcan shipment please inspect for external damage. If no damage is evident on the external packaging, open carton to ensure all ordered items are within the box, and there is no concealed damage to the machine. If the package has suffered rough handling, bumps or damage (visible or concealed), please note it on the bill of lading before accepting the delivery and contact Omcan within 24 hours, so we may initiate a claim with the carrier. A detailed report on the extent of the damage caused to the machine must be filled out within three days, from the delivery date shown in the shipping documents. Omcan has no recourse for damaged products that were shipped collect or third party.

Before operating any equipment, always read and familiarize yourself with all operation and safety instructions.

Omcan would like to thank you for purchasing this machine. It's of the utmost importance to save these instructions for future reference. Also save the original box and packaging for shipping the equipment if servicing or returning of the machine is required.

Omcan Fabrication et distribution Compañie Limité et Food Machinery d'Amerique, dba Omcan et Omcan Inc. ne sont pas responsables de tout dommage ou blessure causé du fait que toute personne ait utilisé cet équipement de façon irrégulière. Le produit ne doit être exploité que par quelqu'un de plus de 18 ans, saine d'esprit, et pas sous l'influence d'une drogue ou d'acohol, qui a été formé pour utiliser cette machine correctement, et est vêtu de vêtements de sécurité approprié. Toute modification de la machine annule toute garantie, et peut causer un préjudice à des personnes utilisant la machine ou des personnes à proximité de la machine pendant son fonctionnement.

VÉRIFIEZ LE COLIS DÈS RÉCEPTION

Dès réception d'une expédition d'Omcan veuillez inspecter pour dommages externes. Si aucun dommage n'est visible sur l'emballage externe, ouvrez le carton afin de s'assurer que tous les éléments commandés sont dans la boîte, et il n'y a aucun dommage dissimulé à la machine. Si le colis n'a subi aucune mauvaises manipulations, de bosses ou de dommages (visible ou cachée), notez-le sur le bond de livraison avant d'accepter la livraison et contactez Omcan dans les 24 heures qui suivent, pour que nous puissions engager une réclamation auprès du transporteur. Un rapport détaillé sur l'étendue des dommages causés à la machine doit être rempli dans un délai de trois jours, à compter de la date de livraison indiquée dans les documents d'expédition. Omcan n'a aucun droit de recours pour les produits endommagés qui ont été expédiées ou cueilli par un tiers transporteur.

General Information

Avant d'utiliser n'importe quel équipement, toujours lire et vous familiariser avec toutes les opérations et les consignes de sécurité.

Omcan voudrais vous remercier d'avoir choisi cette machine. Il est primordial de conserver ces instructions pour une référence ultérieure. Également conservez la boîte originale et l'emballage pour l'expédition de l'équipement si l'entretien ou le retour de la machine est nécessaire.

Omcan Empresa De Fabricacion Y Distribucion Inc. Y Maquinaria De Alimentos De America, Inc. dba Omcan y Omcan Inc. no son responsables de ningun daño o perjuicio causado por cualquier persona inadecuada o el uso descuidado de este equipo. El producto solo podra ser operado por una persona mayor de 18 años, en su sano juicio y no bajo alguna influencia de droga o alcohol, y que este ha sido entrenado en el correcto funcionamiento de esta máquina, y ésta usando ropa apropiada y autorizada. Cualquier modificación a la máquina anula la garantía y puede causar daños a las personas usando la máquina mientras esta en el funcionamiento.

REVISE EL PAQUETE A SU LLEGADA

Tras la recepcion de un envio Omcan favor inspeccionar daños externos. Si no hay daños evidentes en el empaque exterior, Habra el carton para asegurarse que todos los articulos solicitados estén dentro de la caja y no encuentre daños ocultos en la máquina. Si el paquete ha sufrido un manejo de poco cuidado, golpes o daños (visible o oculto) por favor anote en la factura antes de aceptar la entrega y contacte Omcan dentro de las 24 horas, de modo que podamos iniciar una reclamación con la compañía. Un informe detallado sobre los daños causados a la máquina debe ser llenado en el plazo de tres días, desde la fecha de entrega que se muestra en los documentos de envío. Omcan no tiene ningun recurso por productos dañados que se enviaron a recoger por terceros.

Antes de utilizar cualquier equipo, siempre leer y familiarizarse con todas las instrucciones de operación y seguridad.

Omcan quisiera darles las gracias por la compra de esta máquina. Es de la máxima importancia para guardar estas instrucciones para referencias en el futuro. También guarde la caja original y el embalaje para envío del equipo si el mantenimiento o la devolución de la máquina es necesaria.

Safety and Warranty

GENERAL SAFETY REGULATIONS

The slicer must be used only by suitably trained personnel. Furthermore, this personnel must have read this manual carefully. In particular, please comply to the following instructions:

- Install the machine according to the instructions contained in the "Installation" section.
- Do not remove the transparent protections, and do not modify nor exclude the mechanical and electrical



Safety and Warranty

safety devices.

- Do not use the machine with improvised connections, or provisional or non insulated cables.
- Check the power cable and gland plate on the machine body regularly and, when necessary, have them replaced by qualified personnel.
- In case of anomalies, defective operation, incorrect movement, and/or unusual noise, stop the machine immediately.
- Before cleaning or servicing, disconnect the machine from the mains.
- Always use protection gloves during cleaning or maintenance.
- Lay or remove the goods to be sliced on the sliding plate only when the latter is completely pushed back and the thickness control knob positioned to 0.
- To move the carriage tray when slicing, use the handle or the product grip handle.
- For extraordinary maintenance (to replace the sharpener wheels, the blade, etc), please contact the manufacturer or qualified and duly authorized personnel.
- Avoid running the slicers with no product on it.
- The slicers are equipped with a ventilated motor. Extended continual use is not recommended. Let the motor cool down after 30 minutes of use.

RESIDENTIAL USERS: Vendor assumes no liability for parts or labor coverage for component failure or other damages resulting from installation in non-commercial or residential applications. The right is reserved to deny shipment for residential usage; if this occurs, you will be notified as soon as possible.

1 YEAR PARTS AND BENCH WARRANTY

Within the warranty period, contact Omcan Inc. at 1-800-465-0234 to schedule a drop off to either an Omcan authorized service depot in the area, or to an Omcan Service warehouse to repair the equipment.

Unauthorized maintenance will void the warranty. Warranty covers electrical and part failures, not improper use.

Please see <https://omcan.com/disclaimer> for complete info.

WARNING:

The packaging components are classified as normal solid urban waste and can therefore be disposed of without difficulty.

In any case, for suitable recycling, we suggest disposing of the products separately (differentiated waste) according to the current norms.

DO NOT DISCARD ANY PACKAGING MATERIALS IN THE ENVIRONMENT!

Technical Specifications

Model	MS-IT-0300-H	MS-IT-0330-H	MS-IT-0350-PM
Blade Diameter	12" / 300mm	13" / 330mm	14" / 350mm
Power	0.35 HP / 0.26 kW		
Cheese Slicing*			
Slicing Volume*	8 hours or more		
Cutting Size	11" x 9" / 279 x 229mm	11.8" x 9.8" / 300 x 227mm	12.2" x 10.6" / 310 x 270mm
Cut Thickness	0" - 1" / 0 - 25mm		0" - 0.6" / 0 - 15mm
RPM	250		
Electrical	110-120V / 60Hz / 1		
Weight	95 lbs. / 43 kgs.	99 lbs. / 45 kgs.	110 lbs. / 50 kgs.
Packaging Weight	97 lbs. / 44 kgs.	101 lbs. / 46 kgs.	112 lbs. / 51 kgs.
Dimensions	30" x 25.6" x 18.5" 760 x 650 x 470mm	30" x 25.6" x 19" 760 x 650 x 480mm	32.3" x 27" x 20.3" 819 x 686 x 514mm
Packaging Dimensions	33" x 28" x 27" 838 x 710 x 686mm		34" x 31" x 36" 864 x 787 x 914mm
Item Number	13655	13656	13657

*Results may vary due to product consistency and temperature

Installation

UNPACKING

Immediately after unpacking the slicer, check it for possible shipping damage. If this machine is found to be damaged after unpacking, save the packing material and contact the carrier within 15 days of delivery.

Prior to installation, test the electrical service to assure that it agrees with the specifications on the machine data plate.

ELECTRICAL

WARNING: It must be connected to properly grounding plug, grounded outlet. If the receptacle is not the proper grounding type, contact an electrician.

CLEANING

This machine must be thoroughly cleaned and sanitized after installation and before being put into service.

Installation

SAFETY

Safety devices incorporated in this slicer must be in their correct operating positions anytime the slicer is in use.

- The blade cover (6) must be in position over the knife and secured by tightening the hand knob (7).
- The last slice device (4) must be used when slicing it keep your hands away from the knife. When the slicer is not running, the slicer thickness control (2) must be set to zero (fully clockwise) to prevent the blade edge from being exposed.
- Always UNPLUG the power cord before cleaning or moving the slicer.

Operation

- Pull the product holder (3) towards you until it stops and place the product to be sliced on the product holder tray.
- Set the last slice device against the product and switch on the slicer by pressing the on-off switch (9).
- Adjust the slice thickness by turning the slice thickness control.
- The numbers on the slice thickness control do not indicate actual measurements but may be used for reference to duplicate slice thickness.
- Using the last slice device (4), push the product holder (3) back and forth to slice.
- Always switch-off the slicer and turn the slice thickness control clockwise to zero when not slicing.

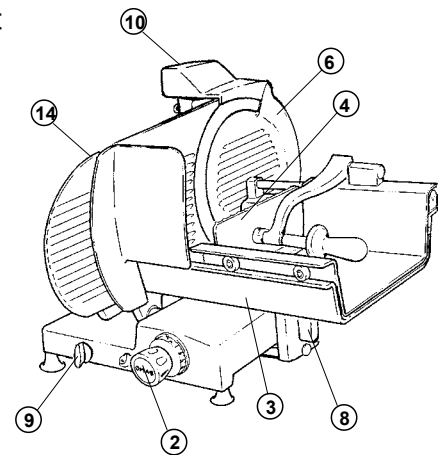

Maintenance

CLEANING

This machine must be thoroughly cleaned after each day's operation or anytime it will not be used for an extended period of time.

WARNING: Unplug machine power cord and turn the index knob fully clockwise before cleaning the slicer.

- Turn the slice deflector (12) for easy cleaning back of the blade.
- The product holder can be removed for an easy cleaning by rotating its handle counterclockwise (8).

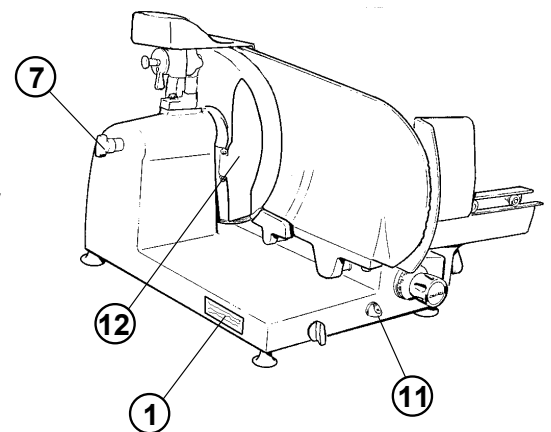

Maintenance

- Using a mild soap, hot water solution, and a clean cloth, wipe all surfaces of the slicer.
- Thoroughly rinse it with another clean cloth and fresh water.
- Remove the blade cover by removing the hand knob (7).
- With the hand knob removed, grasp the edge of the blade cover and carefully lift it straight off the knife.
WARNING: The slicer blade is very sharp. Use extreme caution when working near the blade.
- CAREFULLY wash both sides of the blade with the slice thickness control turned fully clockwise.
- Wash the blade by wiping outward from the center.
- ALWAYS rinse the blade thoroughly using fresh water and a clean cloth. Never use steel pads to clean the blade. Wash and thoroughly rinse the removed components prior to reassembling them.
- DO NOT wash any slicer components in a dishwasher.

BLADE SHARPENING

Attention: Use protection gloves.

Your slicer blade will provide long service in normal deli, food store, or commercial kitchen use. However, in high volume applications where it is a practice to sharpen the blade frequently or even daily, the blade will be expended in a shorter time.

- Before using the sharpener, make sure that the front and back side of the knife edge is clean and free of grease.
- To sharpen knife:
 - a) Be sure that the slicer has been switched off.
 - b) Rotate the slice thickness control (4) into "O" position, so that the thickness plate (5) protects the knife (Fig. 2).
- Lift up the sharpener cover (1) (Fig. 2).
- Disengage the pin (7) and rotate the sharpener (3) (Fig. 3).
- The sharpener, then, goes into its sharpening position (Fig. 4).
- To sharpen, turn the switch first in the ON position, so that the knife turns. Then, slowly rotate the lever which lets both stones go in contact with the knife; sharpening and trimming are made at the same time (Fig. 5).
- Replace the sharpener to normal horizontal position by lifting the pin (7) and close the cover (Fig. 6).
- The grinding stone (6), fitted on its pin, can be easily removed by just drawing it (Fig. 7). To get a nice sharpening, the grinding stone must be clean and free of grease.
- The sharpening time depends on the wear of the knife. To get a good result, the time needed is 10 to 15 seconds. A longer sharpening reduce the duration of the knife and gives no advantage.
- Wipe the slicer with a clean damp cloth to remove any grinding particles.

LUBRICATION

- The rod on which the product holder slides, which is underneath the slicer, should be lubricated weekly with several drops of oil. Stop the carriage at the end of the stroke nearest the operator and pour the lubricant into the special oiler. DO NOT use vegetable oil.
- Occasionally, the slice thickness plate slide rod should be coated lightly with lubricant.
- Turn the slice thickness control fully counterclockwise when lubricating this slide rod and then turn it fully

Maintenance

clockwise when finished. DO NOT lubricate the rod on which the last slice device slides. It must be kept clean but not lubricated. The motor has sealed bearings and requires no lubrication maintenance.

WEAR ADJUSTMENT

After several years of operation and many sharpening of the blade it may become necessary to have the slice thickness plate (14) adjusted closer to the blade.

Illustrated Drawings

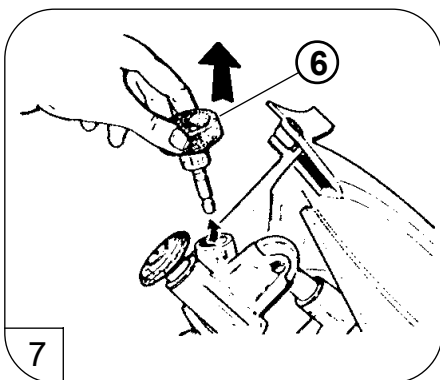
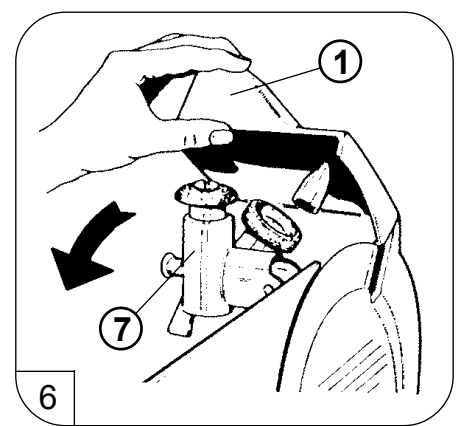
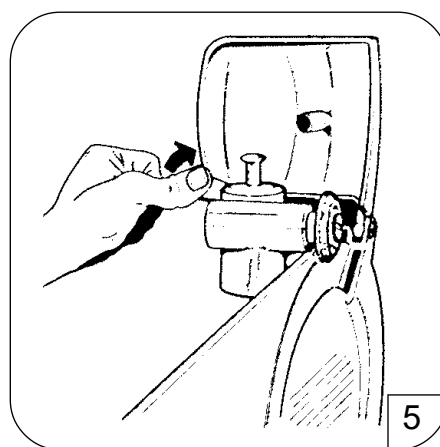
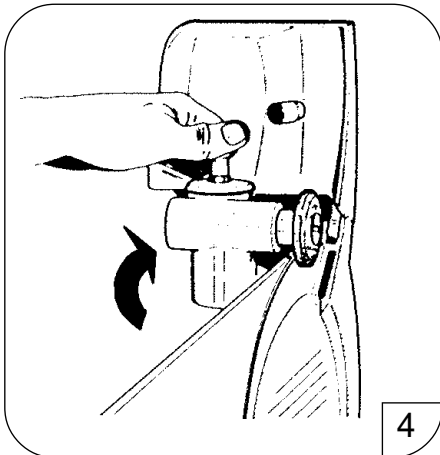
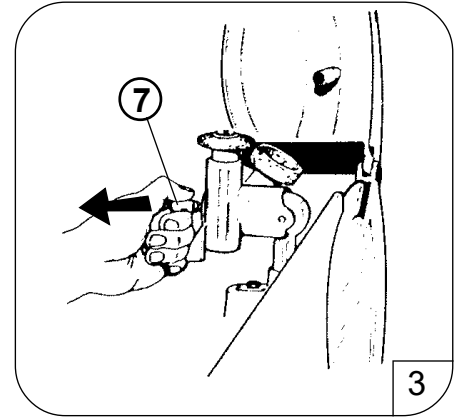
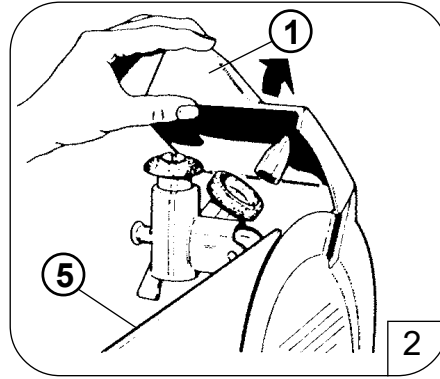
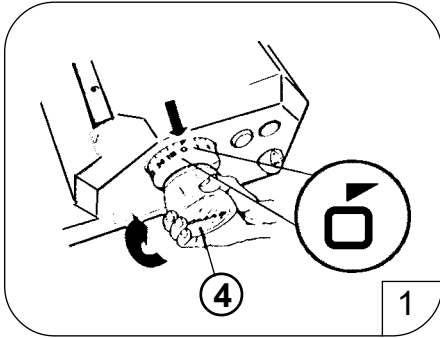

Parts Breakdown

Model MS-IT-0300-H 13655

Model MS-IT-0330-H 13656

Model MS-IT-0350-PM 13657

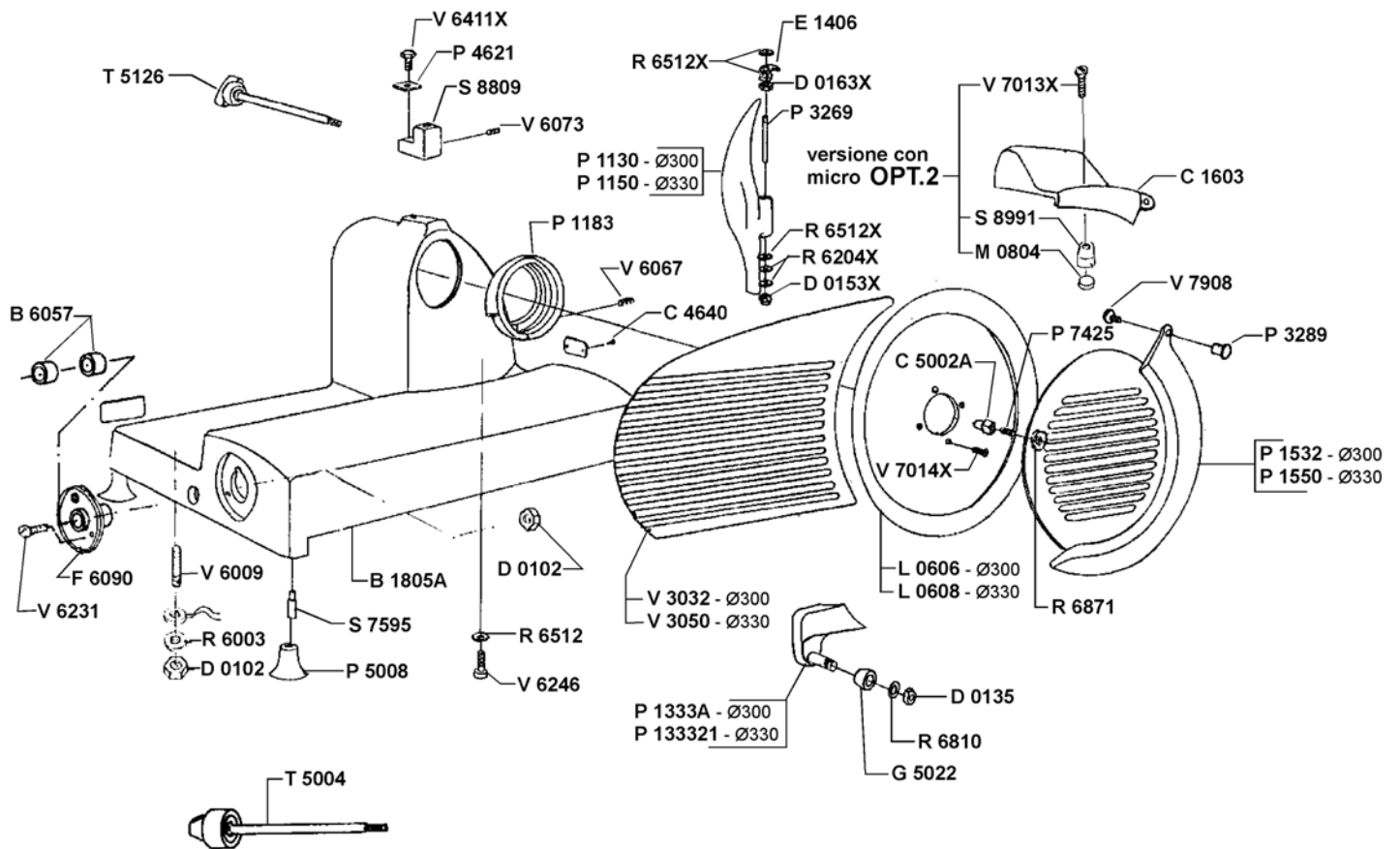

Parts Breakdown

Model MS-IT-0300-H 13655

Model MS-IT-0330-H 13656

Model MS-IT-0350-PM 13657

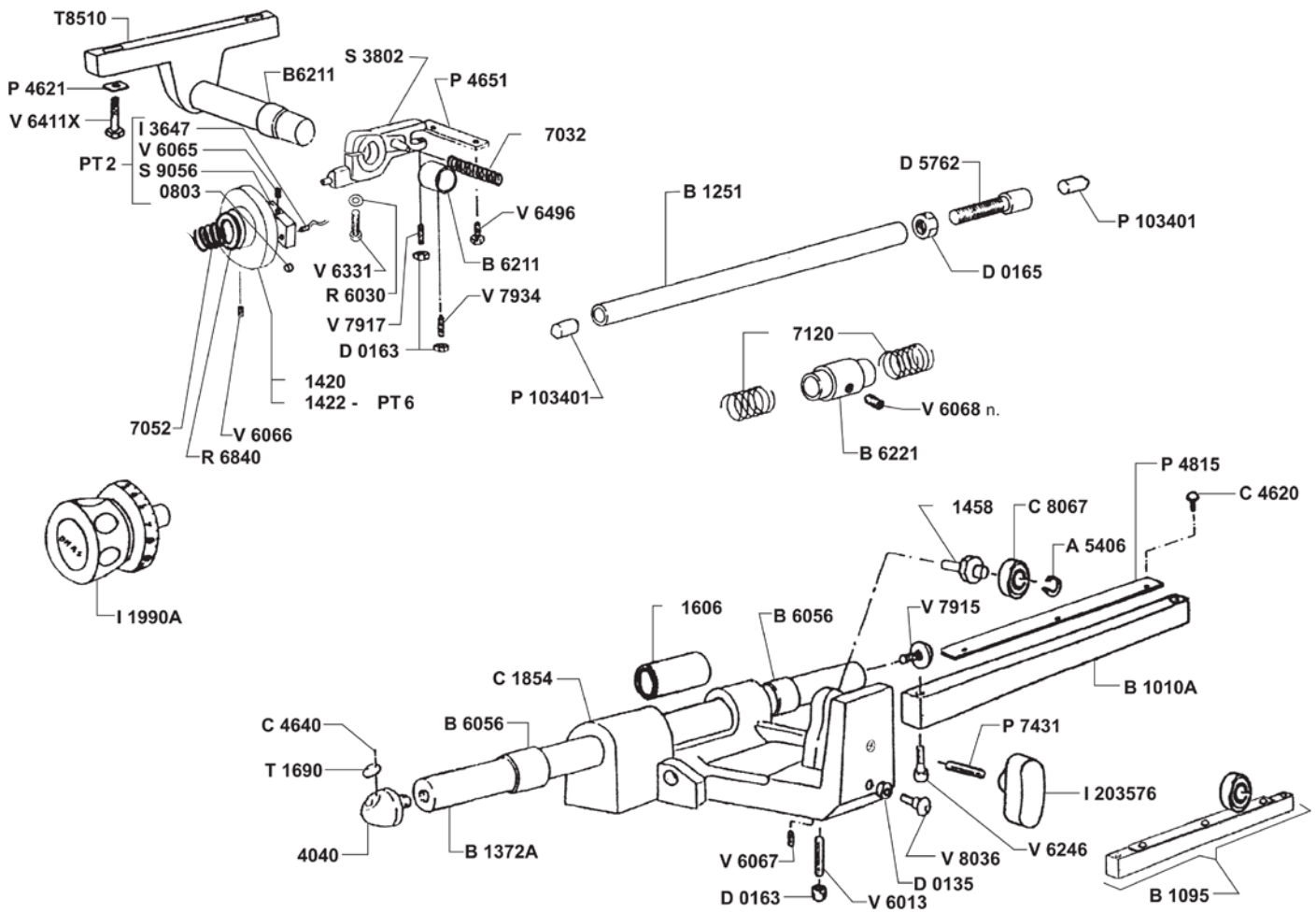

Parts Breakdown

Model MS-IT-0300-H 13655

Model MS-IT-0330-H 13656

Model MS-IT-0350-PM 13657

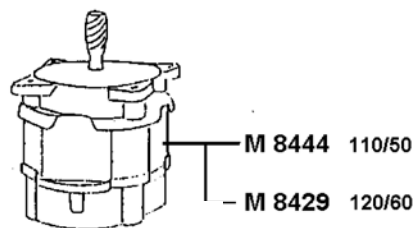
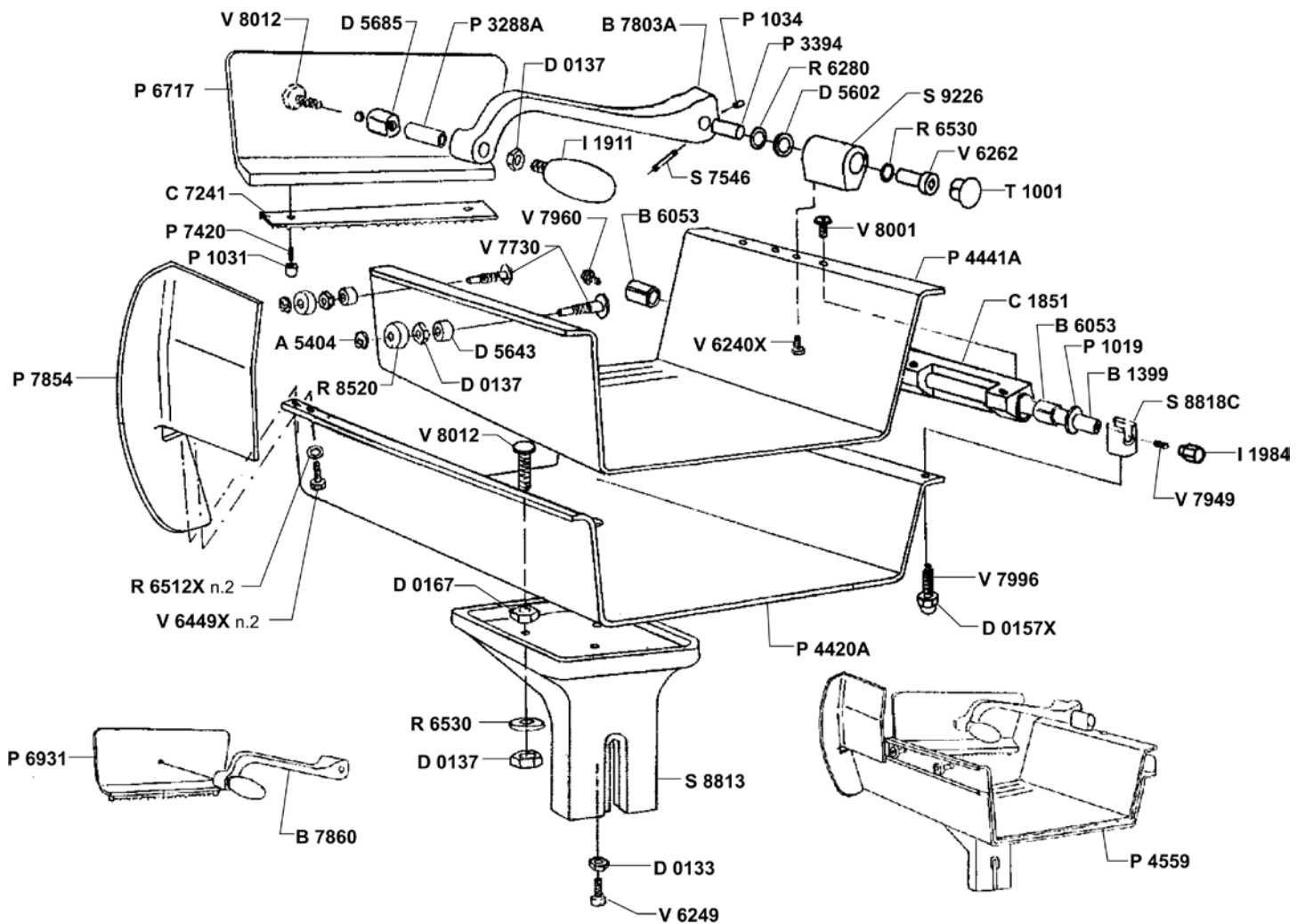

Parts Breakdown

Model MS-IT-0300-H 13655

Model MS-IT-0330-H 13656

Model MS-IT-0350-PM 13657

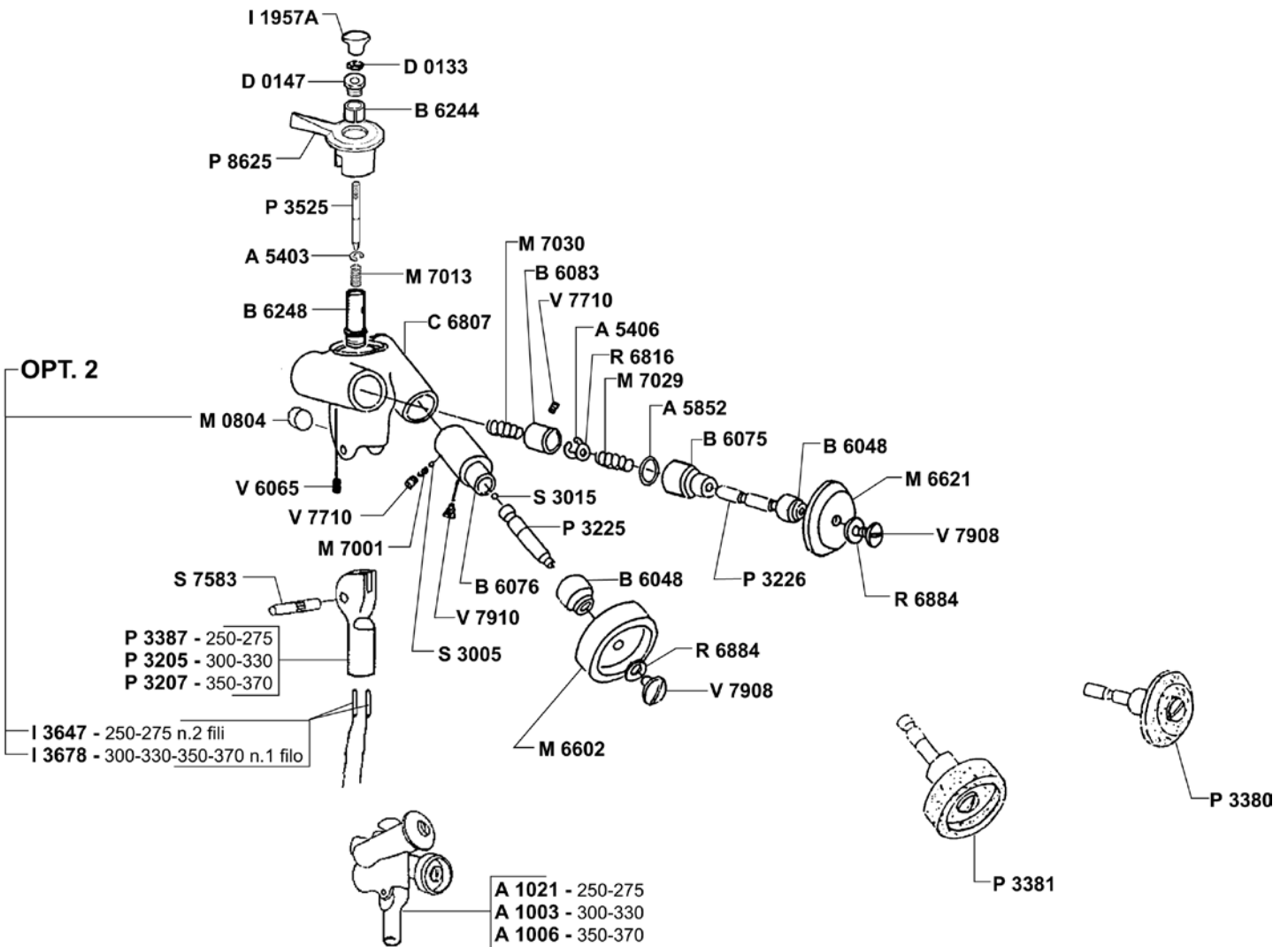

Parts Breakdown

Model MS-IT-0300-H 13655

Model MS-IT-0330-H 13656

Model MS-IT-0350-PM 13657

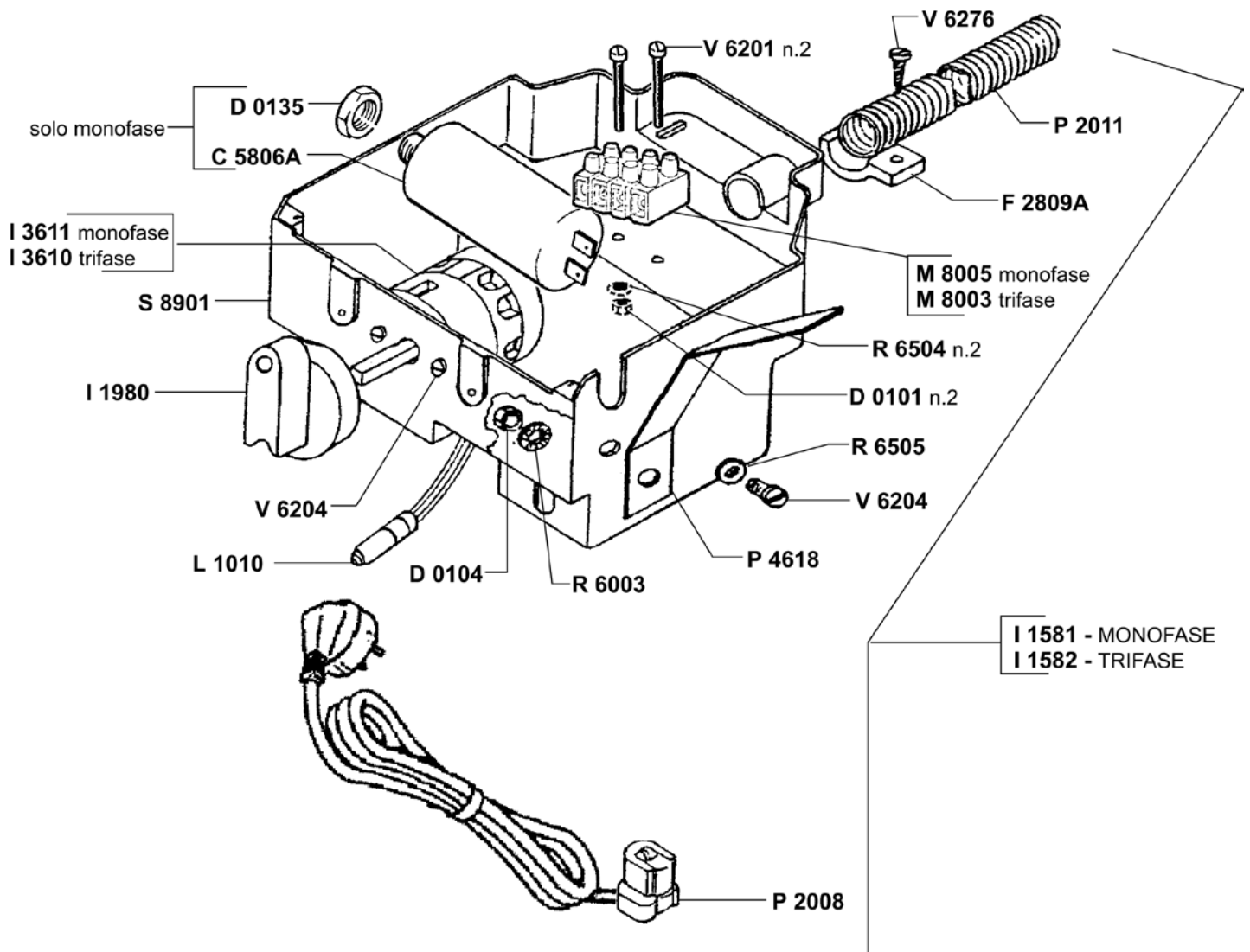

Parts Breakdown

Model MS-IT-0300-H 13655

Model MS-IT-0330-H 13656

Model MS-IT-0350-PM 13657

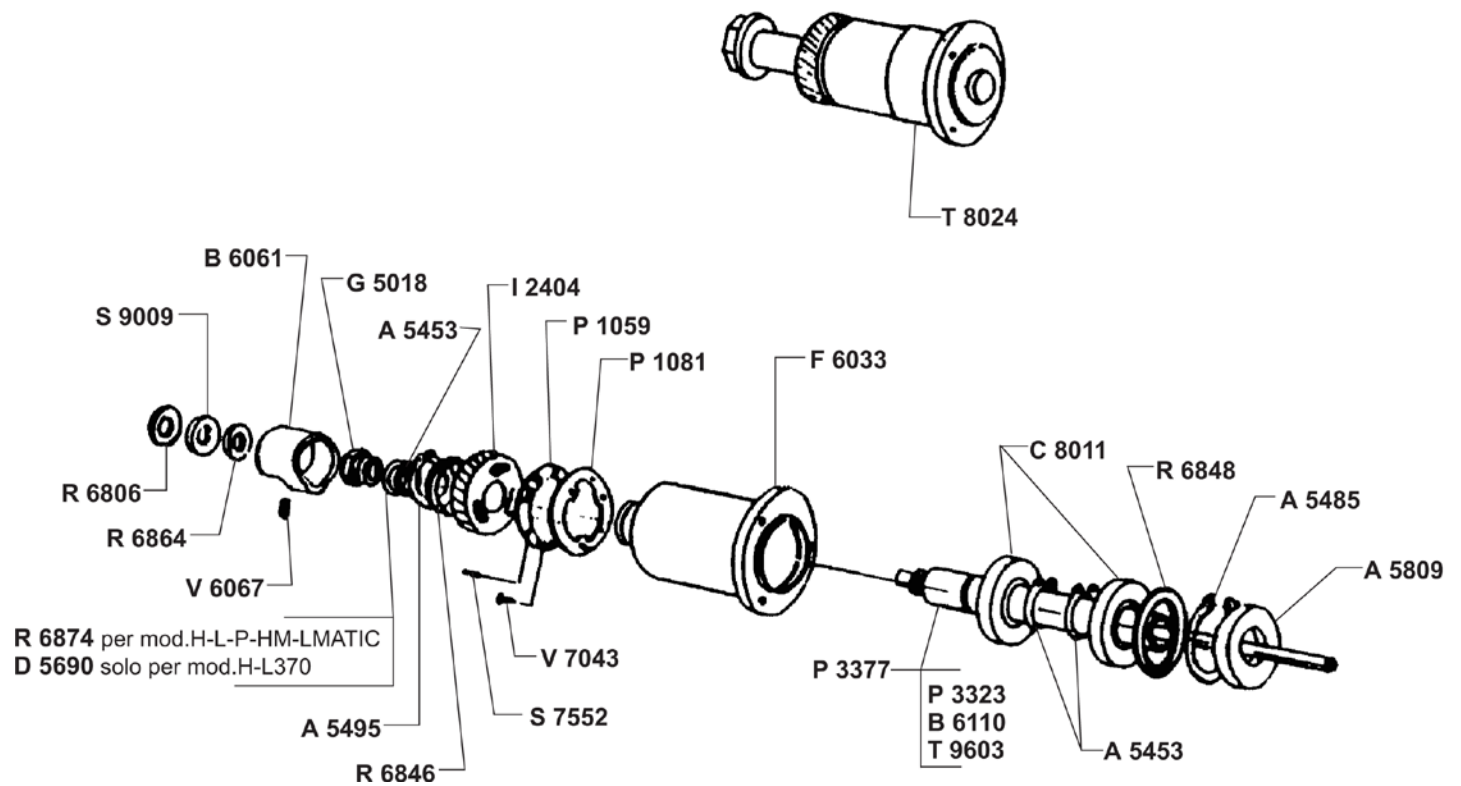



Parts Breakdown

Model MS-IT-0300-H 13655

Item No.	Description	Position	Item No.	Description	Position	Item No.	Description	Position
17272	Sharpening Assembly (Support & Stones) for 13655	A1003	16928	Nut U5589 M6 for 13655	D0133	14787	Grinding Sharpening Stone 48x15x14.3 for 13655	M6602
78234	Sharpener (Support + Stones) for 13655	A1021	19639	Nut M8 for 13655	D0135	36741	Spring 2.9x4x12 Stainless Steel for 13655	M7001
17279	Ring EL.Benzing 5 for 13655	A5403	17337	Nut U5589 M10 6S for 13655	D0137	17377	Spring 8.5x1.0x25 Stainless Steel for 13655	M7013
17280	Ring EL.Benzing 5 for 13655	A5404	36640	Domed Nut U5721 M6 Stainless Steel for 13655	D0153X	17379	Spring 11.9x0.7x27 Stainless Steel for 13655	M7029
16902	Ring EL.Benzing 8 for 13655	A5406	19643	Nut M10 for 13655	D0157X	17380	Spring 13.4x1.3x30 Stainless Steel for 13655	M7030
17281	Ring EL.Seeger Ext.25 for 13655	A5453	19644	Nut M6 for 13655	D0163	19776	Spring 14x1.5x60 for 13655	M7032
19484	Ring 52 for 13655	A5485	36646	Nut U5588 M6 Stainless Steel for 13655	D0163X	17381	Spring 22 5x1 8x18 for 13655	M7052
19612	Ring 33 for 13655	A5495	36647	Nut U5588 M8 for 13655	D0165	19248	Spring 15.6x20x2.2 for 13655	M7120
17283	Oil Seal 25x52x10 for 13655	A5809	19645	Nut M10 for 13655	D0167	20459	Terminal Strip for 13655	M8005
17287	O-Ring 123 17.86x2.62 for 13655	A5852	19547	Nut for 13655	D0190	17385	Motor for 13655	M8429
17290	Carriage Bar for 13655	B1010A	19648	Knife Spacer for 13655	D5602	19791	Oiler Oil Cap with Screw for 13655	O4040
19496	Carriage Rod for 13655	B1095	17341	Spacer D.10.5x14 H.9 for 13655	D5643	17390	Rubber Shock ABS. 16x22x2.5 for 13655	P1019
36548	Shock Absorber Bar 12x170 for 13655	B1251	19553	Meat Grip Spacer H for 13655	D5685	19796	Plastic Shock for 13655	P1031
19507	Carriage Rod A310 for 13655	B1372A	39410	Space Aluminum for 13655	D5690	17392	PL.Shock Absorb.8.5x20 for 13655	P1034
17296	Tray Rod for 13655	B1399	36661	Carriage Shock Absorber Spacer for 13655	D5762	36761	Shock Absorber for 13655	P103401
16904	Bushing Sharpener for 13655	B6048	30459	E1406 Stop Cam for 13655	E1406	16955	Shock Absorber for 13655	P1059
16905	Bushing DU 16x18x15 for 13655	B6053	17342	Cam mm15 for 13655	E1420	17395	Shock Absorber for 13655	P1081
17304	Bushing for 13655	B6056	19559	Cam 25mm for 13655	E1422	17402	Deflector HM-HP for 13655	P1130
17305	Bushing DU 18x20x15 for 13655	B6057	17345	Cam Bearing for 13655	E1458	17406	Ring Deflector for 13655	P1183
19514	Bushing Guard A310 for 13655	B6061	36681	Cord Holder for 13655	F2809A	17410	Blade Guard Cover for 13655	P1532
16906	Bush Sharpening for 13655	B6075	17347	Knife Support Flange for 13655	F6033	17415	Strain Relief for 13655	P2008
16907	Bush Sharpening for 13655	B6076	17349	Handle Flange for 13655	F6090	60421	Electrical Conduit for 13655	P2011
17307	Bushing Sharp. for 13655	B6083	17351	Locknut for 13655	G5018	19811	Pin Sharpener for 13655	P3205
78265	Bushing Funnel for 13655	B6110	36688	Locknut for 13655	G5022	16959	Pin Grinding for 13655	P3225
17312	Bushing 22x25x20 for 13655	B6211	17355	Handle for 13655	I1911	17419	Pin Truing for 13655	P322601
36566	Bushing to hold Carriage Springs for 13655	B6221	19587	Sharpener Knob for 13655	I1957A	17422	Pin Deflector for 13655	P3269
17313	Bushing DU 14x15x16 for 13655	B6244	36707	Switch Handle for 13655	I1980	19822	Pin Handle Meat Grip for 13655	P3288A
36577	Meat Grip Arm for 13655	B7803A	18222	Rod Meat Grip Handle H for 13655	I1984	19824	Pin Guard Knife for 13655	P3377
16909	Sharpener Cover for 13655	C1603	62453	Nylon Gear for 13655	I2404	17426	Assembly Honing Stone Pivot for 13655	P3380
36590	Carriage for 13655	C1854	78585	Switch 380/50/3 for 13655	I3610	17427	Assembly Grinding Stone & Pin for 13655	P3381
20423	Pin for 13655	C4620	16938	Switch and Knob for 13655	I3611	78233	Pin Sharpener for 13655	P3387
36601	Rivet 1.9x5 for 13655	C4640	17369	Switch 4x20 for 13655	I3647	19825	Pin Support Meat Grip for 13655	P3394
17325	Capacitor 8uf for 13655	C5806	36723	Switch 4x25 for 13655	I3678	36801	Pivot Sgancio Sharpener for 13655	P3525
19534	Housing Sharpener for 13655	C6807	13593	Blade 57x4x254x22 for 13655	L0606	36808	Tray for 13655	P4420A
19535	Rack for 13655	C7241	36731	Lamp 220V. for 13655	L1010	36811	Tray for 13655	P4441A
19637	Nut M3 for 13655	D0101	36733	Magnet 8x10 for 13655	M0803	36823	Tray Assembly for 13655	P4559
36634	Nut U5587 M3.5 for 13655	D0104	36734	Magnet 12x6 for 13655	M0804	36824	EL. Box Flat Bar for 13655	P4618

Parts Breakdown

Model MS-IT-0300-H 13655

Item No.	Description	Position	Item No.	Description	Position	Item No.	Description	Position
19831	Gauge Plate Flat Bar VS for 13655	P4621	78576	Washer for 13655	R6931	37032	Screw TC 6107 M3x20 for 13655	V6201
19832	Flat Bar for 13655	P4651	16973	Plate Wheel D.25x9.5 for 13655	R8520	19696	Screw M3.5x12 for 13655	V6204
18221	Slide Rail Flat 20x400 for 13655	P4815	19680	Ball 3 17 for 13655	S3005	19699	Screw M4x25 for 13655	V6231
16961	Foot for 13655	P5008	17465	Ball 4.76 for 13655	S3015	37037	Screw TCEI U5931 M6x16 for 13655	V6240X
36844	End Grip Assembly for 13655	P6717	36924	Pin M.E.U6875 6x30 for 13655	S7546	19702	Screw M6x25 for 13655	V6246
19655	Meat Grip Stud H for 13655	P7420	19688	Pin 2x12 for 13655	S7552	19704	Screw M10x16 for 13655	V6262
16964	Stud Guard Knife C for 13655	P7425	17475	Pin 8x42 for 13655	S7583	37047	Screw TC AUT.D7971 2.9x13 for 13655	V6276
17444	Stud Carriage for 13655	P7431	17476	Foot Support Pin D.10 M8 L.37 for 13655	S7595	19913	Screw M8x45 for 13655	V6331
36854	Thumb Protection for 13655	P7854	19871	Bracket Sharpener for 13655	S8809	37061	Screw TE U5739 M8x35 Inox for 13655	V6411X
24030	Sharpener Operating Handle for 13655	P8625	36936	Bracket Tray for 13655	S8813	37070	Screw TE U5739 M6x20 Stainless Steel for 13655	V6449X
19657	Washer 4 for 13655	R6003	36937	Bracket for Plate Rod for 13655	S8818C	37076	Screw TE TRILD.7976 M6x15 for 13655	V6496
19661	Washer 8 for 13655	R6030	19873	EL Box Bracket for 13655	S8901	37078	Stainless Steel Screw TSP U6109 M5x12 for 13655	V7013X
36876	Washer 6.2x12.5x0.7 Stainless Steel for 13655	R6204X	36952	Magnet Support for 13655	S8991	17498	Screw TSPEI U5933 M4x10 for 13655	V7043
19666	Washer for 13655	R6280	77597	Washer Bracket A310 for 13655	S9009	19713	Screw Sharpener for 13655	V7710
36880	Washer U6592 3 for 13655	R6504	24158	Pusher Rod Support for 13655	S9226	37091	Screw H for 13655	V7730
16967	Washer U65926 for 13655	R6512	19877	Rubber Cap for 13655	T1001	17503	Screw M5x13 for 13655	V7908
17457	Washer U6592 6 Stainless Steel for 13655	R6512X	20265	Tierod for 13655	T5004	19715	Screw Sharpener for 13655	V7910
19668	Washer 10 for 13655	R6530	17491	Knife Shaft Assembly for 13655	T8024	17504	Bar Screw M6x14 Stainless Steel for 13655	V7915
17458	Contact Washer for 13655	R6806	24033	Bracket for 13655	T8510	19717	Screw M6x50 for 13655	V7917
36889	Washer 10.5x16x1 for 13655	R6816	78586	Plastic Bar lg.200 for 13655	T9603	19720	Screw M6 for 13655	V7934
16969	Washer 18.2x25x0.5 for 13655	R6840	37004	Gauge Plate for 13655	V3032	19917	Screw BS for 13655	V7960
17460	Washer 34.2x46x0.5 for 13655	R6846	37017	Screw STTC U6113 M4x30 for 13655	V6009	19724	Screw H for 13655	V8001
19674	Washer 44.5x51.5x0.2 for 13655	R6848	37023	Screw STEI U5929 M5x5 for 13655	V6065	37098	Screw M10x40 for 13655	V8012
77596	Switch Washer A310 for 13655	R6864	19691	Grub Screw M6x6 for 13655	V6066	19920	Screw M8x30 for 13655	V8036
36892	Washer 17x30x4 for 13655	R6874	19692	Screw M6x8 for 13655	V6067			
16972	Washer 5.5x19x2.5 for 13655	R6884	23648	Screw for 13655	V6073			



Parts Breakdown

Model MS-IT-0330-H 13656

Item No.	Description	Position	Item No.	Description	Position	Item No.	Description	Position
17272	Sharpening Assembly (Support & Stones) for 13656	A1003	19639	Nut M8 for 13656	D0135	17377	Spring 8.5x1.0x25 Stainless Steel for 13656	M7013
78234	Sharpener (Support + Stones) for 13656	A1021	17337	Nut U5589 M10 6S for 13656	D0137	17379	Spring 11.9x0.7x27 Stainless Steel for 13656	M7029
17279	Ring EL.Benzing 5 for 13656	A5403	36640	Domed Nut U5721 M6 Stainless Steel for 13656	D0153X	17380	Spring 13.4x1.3x30 Stainless Steel for 13656	M7030
17280	Ring EL.Benzing 5 for 13656	A5404	19643	Nut M10 for 13656	D0157X	19776	Spring 14 x 1.5 x 60 for 13656	M7032
16902	Ring EL.Benzing 8 for 13656	A5406	19644	Nut M6 for 13656	D0163	17381	Spring 22 5x1 8x18 for 13656	M7052
17281	Ring EL.Seeger Ext.25 for 13656	A5453	36646	Nut U5588 M6 Stainless Steel for 13656	D0163X	19248	Spring 15.6x20x2.2 for 13656	M7120
19484	Ring 52 for 13656	A5485	36647	Nut U5588 M8 for 13656	D0165	20459	Terminal Strip for 13656	M8005
19612	Ring 33 for 13656	A5495	19645	Nut M10 for 13656	D0167	19791	Oiler Oil Cap with Screw for 13656	O4040
17283	Oil Seal 25x52x10 for 13656	A5809	19547	Nut for 13656	D0190	17390	Rubber Shock Abs. 16x22x2.5 for 13656	P1019
17287	O-Ring 123 17.86x2.62 for 13656	A5852	19648	Knife Spacer for 13656	D5602	19796	Plastic Shock for 13656	P1031
17290	Carriage Bar for 13656	B1010A	17341	Spacer D.10.5x14 H.9 for 13656	D5643	17392	Pl.Shock Absorb.8.5x20 for 13656	P1034
19496	Carriage Rod for 13656	B1095	19553	Meat Grip Spacer H for 13656	D5685	36761	Shock Absorber for 13656	P103401
36548	Shock Absorber Bar 12x170 for 13656	B1251	39410	Space Aluminum for 13656	D5690	16955	Shock Absorber for 13656	P1059
19507	Carriage Rod A310 for 13656	B1372A	36661	Carriage Shock Absorber Spacer for 13656	D5762	17395	Shock Absorber for 13656	P1081
17296	Tray Rod for 13656	B1399	30459	E1406 Stop Cam for 13656	E1406	19805	Deflector for 13656	P1150
16904	Bushing Sharpener for 13656	B6048	17342	Cam mm15 for 13656	E1420	17406	Slicer Deflector for 13656	P1183
16905	Bushing DU 16x18x15 for 13656	B6053	19559	Cam 25mm for 13656	E1422	36764	Slice Deflector for 13656	P133321
17304	Bushing for 13656	B6056	17345	Cam Bearing for 13656	E1458	17412	Knife Guard for 13656	P1550
17305	Bushing DU 18x20x15 for 13656	B6057	36681	Cord Holder for 13656	F2809A	17415	Strain Relief for 13656	P2008
19514	Bushing Guard A310 for 13656	B6061	17347	Knife Support Flange for 13656	F6033	60421	Electrical Conduit for 13656	P2011
16906	Bush Sharpening for 13656	B6075	17349	Handle Flange for 13656	F6090	19811	Pin Sharpener for 13656	P3205
16907	Bush Sharpening for 13656	B6076	17351	Locknut for 13656	G5018	16959	Pin Grinding for 13656	P3225
17307	Bushing Sharp. for 13656	B6083	36688	Locknut for 13656	G5022	17419	Pin Truing for 13656	P322601
78265	Bushing Funnel for 13656	B6110	17355	Handle for 13656	I1911	17422	Pin Deflector for 13656	P3269
17312	Bushing 22x25x20 for 13656	B6211	19587	Sharpener Knob for 13656	I1957A	19822	Pin Handle Meat Grip for 13656	P3288A
36566	Bushing to hold Carriage Springs for 13656	B6221	36707	Switch Handle for 13656	I1980	19824	Pin Guard Knife for 13656	P3377
17313	Bushing DU 14x15x16 for 13656	B6244	18222	Rod Meat Grip Handle for 13656	I1984	17426	Assy Honing Stone Pivot for 13656	P3380
36577	Meat Grip Arm for 13656	B7803A	62453	Nylon Gear for 13656	I2404	17427	Assy Grinding Stone & Pin for 13656	P3381
16909	Sharpener Cover for 13656	C1603	78585	Switch 380/50/3 for 13656	I3610	78233	Pin Sharpener for 13656	P3387
36590	Carriage for 13656	C1854	16938	Switch and Knob for 13656	I3611	19825	Pin Support Meat Grip for 13656	P3394
20423	Pin for 13656	C4620	17369	Switch 4x20 for 13656	I3647	36801	Pivot Sgancio Sharpener for 13656	P3525
36601	Rivet 1.9x5 for 13656	C4640	36723	Switch 4x25 for 13656	I3678	36808	Tray for 13656	P4420A
17325	Capacitor 8uf for 13656	C5806	13598	Blade 330 57x4x270 for 13656	L0608	36811	Tray for 13656	P4441A
19534	Housing Sharpener H for 13656	C6807	36731	Lamp 220V. for 13656	L1010	36823	Tray Assy for 13656	P4559
19535	Rack for 13656	C7241	36733	Magnet 8x10 for 13656	M0803	36824	El. Box Flat Bar for 13656	P4618
19637	Nut M3 for 13656	D0101	36734	Magnet 12x6 for 13656	M0804	19831	Gauge Plate Flat Bar VS for 13656	P4621
36634	Nut U5587 M3.5 for 13656	D0104	14787	Grinding Sharpening Stone 48x15x14.3 for 13656	M6602	19832	Flat Bar for 13656	P4651
16928	Nut U5589 M6 for 13656	D0133	36741	Spring 2.9x4x12 Stainless Steel for 13656	M7001	18221	Slide Rail Flat 20x400 for 13656	P4815

Parts Breakdown

Model MS-IT-0330-H 13656

Item No.	Description	Position	Item No.	Description	Position	Item No.	Description	Position
16961	Foot for 13656	P5008	19680	Ball 3 17 for 13656	S3005	19696	Screw M3.5x12 for 13656	V6204
36844	End Grip Assembly for 13656	P6717	17465	Ball 4.76 for 13656	S3015	19699	Screw M4x25 for 13656	V6231
19655	Meat Grip Stud for 13656	P7420	36924	Pin M.E. U6875 6x30 for 13656	S7546	37037	Screw TCEI U5931 M6x16 for 13656	V6240X
16964	Stud Guard Knife C for 13656	P7425	19688	Pin 2x12 for 13656	S7552	19702	Screw M6x25 for 13656	V6246
17444	Stud Carriage for 13656	P7431	17475	Pin 8x42 for 13656	S7583	19704	Screw M10x16 for 13656	V6262
36854	Thumb Protection for 13656	P7854	17476	Foot Support Pin D.10 M8 L.37 for 13656	S7595	37047	Screw TC AUT.D7971 2.9 x 13 for 13656	V6276
24030	Sharpener Operating Handle for 13656	P8625	19871	Bracket Sharpener for 13656	S8809	19913	Screw M8x45 for 13656	V6331
19657	Washer 4 for 13656	R6003	36936	Bracket Tray for 13656	S8813	37061	Screw TE U5739 M8x35 Inox for 13656	V6411X
19661	Washer 8 for 13656	R6030	36937	Bracket for H Series Plate Rod for 13656	S8818C	37070	Stainless Steel Screw TE U5739 M6x20 for 13656	V6449X
36876	Washer 6.2x12.5x0.7 Stainless Steel for 13656	R6204X	19873	EI Box Bracket for 13656	S8901	37076	Screw TE Tril.D7976 M6x15 for 13656	V6496
19666	Washer for 13656	R6280	36952	Magnet Support for 13656	S8991	37078	Stainless Steel Screw TSP U6109 M5x12 for 13656	V7013X
36880	Washer U6592 3 for 13656	R6504	77597	Washer Bracket A310 for 13656	S9009	17498	Screw TSPEI U5933 M4x10 for 13656	V7043
16967	Washer U65926 for 13656	R6512	24158	Pusher Rod Support for 13656	S9226	19713	Screw Sharpener for 13656	V7710
17457	Washer U6592 6 Stainless Steel for 13656	R6512X	19877	Rubber Cap for 13656	T1001	37091	Screw H for 13656	V7730
19668	Washer 10 for 13656	R6530	20265	Tierod for 13656	T5004	17503	Screw M5x13 for 13656	V7908
17458	Contact Washer for 13656	R6806	17491	Knife Shaft Assy for 13656	T8024	19715	Screw Sharpener for 13656	V7910
36889	Washer 10.5x16x1 for 13656	R6816	24033	Bracket for 13656	T8510	17504	Bar Screw M6x14 Stainless Steel for 13656	V7915
16969	Washer 18.2x25x0.5 for 13656	R6840	78586	Plastic Bar lg.200 for 13656	T9603	19717	Screw M6x50 for 13656	V7917
17460	Washer 34.2x46x0.5 for 13656	R6846	37006	Gauge Plate for 13656	V3050	19720	Screw M6 for 13656	V7934
19674	Washer 44.5x51.5x0.2 for 13656	R6848	37017	Screw STTC U6113 M4x30 for 13656	V6009	19917	Screw BS for 13656	V7960
77596	Switch Washer A310 for 13656	R6864	37023	Screw STEI U5929 M5x5 for 13656	V6065	19724	Screw H for 13656	V8001
36892	Washer 17x30x4 for 13656	R6874	19691	Grub Screw M6x6 for 13656	V6066	37098	Screw M10x40 for 13656	V8012
16972	Washer 5.5x19x2.5 for 13656	R6884	19692	Screw M6x8 for 13656	V6067	19920	Screw M8x30 for 13656	V8036
78576	Washer for 13656	R6931	23648	Screw For H350 for 13656	V6073			
16973	Plate Wheel D.25x9.5 for 13656	R8520	37032	Screw TC 6107 M3x20 for 13656	V6201			

Parts Breakdown

Model MS-IT-0350-PM 13657

Item No.	Description	Position	Item No.	Description	Position	Item No.	Description	Position
16899	Sharpening Assy for 13657	A1006	16928	Nut U5589 M6 for 13657	D0133	36741	Spring 2.9x4x12 Stainless Steel for 13657	M7001
78234	Sharpener (Support + Stones) for 13657	A1021	19639	Nut M8 for 13657	D0135	17377	Spring 8.5x1.0x25 Stainless Steel for 13657	M7013
17279	Ring El.Benzing 5 for 13657	A5403	17337	Nut U5589 M10 6S for 13657	D0137	17379	Spring 11.9x0.7x27 Stainless Steel for 13657	M7029
17280	Ring El Benzing 5 for 13657	A5404	36640	Domed Nut U5721 M6 Stainless Steel for 13657	D0153X	17380	Spring 13.4x1.3x30 Stainless Steel for 13657	M7030
16902	Ring El.Benzing 8 for 13657	A5406	19643	Nut M10 for 13657	D0157X	19776	Spring 14x1.5x60 for 13657	M7032
17281	Ring El.Seeger Ext.25 for 13657	A5453	19644	Nut M6 for 13657	D0163	17381	Spring 22 5x1 8x18 for 13657	M7052
19484	Ring 52 for 13657	A5485	36646	Nut U5588 M6 Stainless Steel for 13657	D0163X	19248	Spring 15.6x20x2.2 for 13657	M7120
19612	Ring 33 for 13657	A5495	36647	Nut U5588 M8 for 13657	D0165	20459	Terminal Strip for 13657	M8005
17283	Oil Seal 25x52x10 for 13657	A5809	19645	Nut M10 for 13657	D0167	19791	Oiler Oil Cap with Screw for 13657	O4040
17287	O-Ring 123 17.86x2.62 for 13657	A5852	19547	Nut for 13657	D0190	17390	Rubber Shock ABS. 16x22x2.5 for 13657	P1019
17290	Carriage Bar for 13657	B1010A	19648	Knife Spacer for 13657	D5602	19796	Plastic Shock for 13657	P1031
19496	Carriage Rod for 13657	B1095	17341	Spacer D.10.5x14 H.9 for 13657	D5643	17392	Pl.Shock Absorb.8.5x20 for 13657	P1034
36548	Shock Absorber Bar 12x170 for 13657	B1251	19553	Meat Grip Spacer for 13657	D5685	36761	Shock Absorber for 13657	P103401
19507	Carriage Rod A310 for 13657	B1372A	39410	Space Aluminum for 13657	D5690	16955	Shock Absorber for 13657	P1059
17296	Tray Rod for 13657	B1399	36661	Carriage Shock Absorber Spacer for 13657	D5762	17395	Shock Absorber for 13657	P1081
16904	Bushing Sharpener for 13657	B6048	30459	E1406 Stop Cam for 13657	E1406	19805	Deflector for 13657	P1150
16905	Bushing DU 16x18x15 for 13657	B6053	17342	Cam mm15 for 13657	E1420	27888	Ring Deflector for 13657	P1183
17304	Bushing for 13657	B6056	19559	Cam 25mm for 13657	E1422	36764	Slice Deflector for 13657	P133321
17305	Bushing DU 18x20x15 for 13657	B6057	17345	Cam Bearing for 13657	E1458	17412	Knife Guard for 13657	P1550
19514	Bushing Guard A310 for 13657	B6061	36681	Cord Holder for 13657	F2809A	17415	Strain Relief for 13657	P2008
16906	Bush Sharpening for 13657	B6075	17347	Knife Support Flange for 13657	F6033	60421	Electrical Conduit for 13657	P2011
16907	Bush. Sharpening for 13657	B6076	17349	Handle Flange for 13657	F6090	17416	Pin Sharpener for 13657	P3207
17307	Bushing Sharp. for 13657	B6083	17351	Locknut for 13657	G5018	16959	Pin Grinding for 13657	P3225
78265	Bushing Funnel for 13657	B6110	36688	Locknut for 13657	G5022	17419	Pin Truing for 13657	P322601
17312	Bushing 22x25x20 for 13657	B6211	17355	Handle for 13657	I1911	17422	Pin Deflector for 13657	P3269
36566	Bushing to Hold Carriage Springs for 13657	B6221	19587	Sharpener Knob for 13657	I1957A	19822	Pin Handle Meat Grip for 13657	P3288A
17313	Bushing DU 14x15x16 for 13657	B6244	36707	Switch Handle for 13657	I1980	19824	Pin Guard Knife for 13657	P3377
36577	Meat Grip Arm for 13657	B7803A	18222	Rod Meat Grip Handle H for 13657	I1984	17426	Assy Honing Stone Pivot for 13657	P3380
16909	Sharpener Cover for 13657	C1603	62453	Nylon Gear for 13657	I2404	17427	Assy Grinding Stone & Pin for 13657	P3381
36590	Carriage for 13657	C1854	78585	Switch 380/50/3 for 13657	I3610	78233	Pin Sharpener for 13657	P3387
20423	Pin for 13657	C4620	16938	Switch and Knob for 13657	I3611	19825	Pin Support Meat Grip for 13657	P3394
36601	Rivet 1.9x5 for 13657	C4640	17369	Switch 4x20 for 13657	I3647	36801	Pivot Sgancio Sharpener for 13657	P3525
17325	Capacitor 8uf for 13657	C5806	36723	Switch 4x25 for 13657	I3678	36808	Tray for 13657	P4420A
19534	Housing Sharpener for 13657	C6807	13599	Blade 350x57x4x280 for 13657	L0608	36811	Tray for 13657	P4441A
19535	Rack for 13657	C7241	36731	Lamp 220V. for 13657	L1010	36823	Tray Assy for 13657	P4559
17334	Bearing 2Z-6205 25x52x15 for 13657	C8011	36733	Magnet 8x10 for 13657	M0803	36824	El. Box Flat Bar for 13657	P4618
19637	Nut M3 for 13657	D0101	36734	Magnet 12x6 for 13657	M0804	19831	Gauge Plate Flat Bar VS for 13657	P4621
36634	Nut U5587 M3.5 for 13657	D0104	14787	Grinding Sharpening Stone 48x15x14.3 for 13657	M6602	19832	Flat Bar for 13657	P4651

Parts Breakdown

Model MS-IT-0350-PM 13657

Item No.	Description	Position	Item No.	Description	Position	Item No.	Description	Position
18221	Slide Rail Flat 20x400 for 13657	P4815	16973	Plate Wheel D.25x9.5 for 13657	R8520	37032	Screw TC 6107 M3x20 for 13657	V6201
16961	Foot for 13657	P5008	19680	Ball 3 17 for 13657	S3005	19696	Screw M3.5x12 for 13657	V6204
36844	End Grip Assy for 13657	P6717	17465	Ball 4.76 for 13657	S3015	19699	Screw M4x25 for 13657	V6231
19655	Meat Grip Stud for 13657	P7420	36924	Pin M.E.U6875 6x30 for 13657	S7546	37037	Screw TCEI U5931 M6x16 for 13657	V6240X
16964	Stud Guard Knife for 13657	P7425	19688	Pin 2x12 for 13657	S7552	19702	Screw M6x25 for 13657	V6246
17444	Stud Carriage for 13657	P7431	17475	Pin 8x42x	S7583	19704	Screw M10x16 for 13657	V6262
36854	Thumb Protection for 13657	P7854	17476	Foot Support Pin D.10 M8 L.37 for 13657	S7595	37047	Screw TC AUT.D7971 2.9x13 for 13657	V6276
24030	Sharpener Operating Handle for 13657	P8625	19871	Bracket Sharpener HLC for 13657	S8809	19913	Screw M8x45 for 13657	V6331
19657	Washer 4 for 13657	R6003	36936	Bracket.Tray for 13657	S8813	37061	Screw TE U5739 M8x35 Inox for 13657	V6411X
19661	Washer 8 for 13657	R6030	36937	Bracket for Plate Rod for 13657	S8818C	37070	Screw TE U5739 M6x20 Stainless Steel for 13657	V6449X
36876	Washer 6.2x12.5x0.7 Stainless Steel for 13657	R6204X	19873	EI Box Bracket for 13657	S8901	37076	Screw TE Tril.D7976 M6x15 for 13657	V6496
19666	Washer for 13657	R6280	36952	Magnet Support	S8991	37078	Stainless Steel Screw TSP U6109 M5x12 for 13657	V7013X
36880	Washer U6592 3 for 13657	R6504	77597	Washer Bracket A310 for 13657	S9009	17498	Screw TSPEI U5933 M4x10 for 13657	V7043
16967	Washer U65926 for 13657	R6512	24158	Pusher Rod Support for 13657	S9226	19713	Screw Sharpener for 13657	V7710
17457	Washer U6592 6 Stainless Steel for 13657	R6512X	19877	Rubber Cap for 13657	T1001	37091	Screw H for 13657	V7730
19668	Washer 10 for 13657	R6530	20265	Tierod for 13657	T5004	17503	Screw M5x13 for 13657	V7908
17458	Contact Washer for 13657	R6806	17491	Knife Shaft Assy for 13657	T8024	19715	Screw Sharpener for 13657	V7910
36889	Washer 10.5x16x1 for 13657	R6816	24033	Bracket for 13657	T8510	17504	Bar Screw M6x14 Stainless Steel for 13657	V7915
16969	Washer 18.2x25x0.5 for 13657	R6840	78586	Plastic Bar lg.200 for 13657	T9603	19717	Screw M6x50 for 13657	V7917
17460	Washer 34.2x46x0.5 for 13657	R6846	37006	Gauge Plate for 13657	V3050	19720	Screw M6 for 13657	V7934
19674	Washer 44.5x51.5x0.2 for 13657	R6848	37017	Screw STTC U6113 M4x30 for 13657	V6009	19917	Screw BS for 13657	V7960
77596	Switch Washer A310 for 13657	R6864	37023	Screw STEI U5929 M5x5 for 13657	V6065	19724	Screw H for 13657	V8001
36892	Washer 17x30x4 for 13657	R6874	19691	Grub Screw M6x6 for 13657	V6066	37098	Screw M10x40 for 13657	V8012
16972	Washer 5.5x19x2.5 for 13657	R6884	19692	Screw M6x8 for 13657	V6067	19920	Screw M8x30 for 13657	V8036
78576	Washer for 13657	R6931	23648	Screw for 13657	V6073			

Electrical Schematics

Model MS-IT-0300-H 13655

Model MS-IT-0330-H 13656

Model MS-IT-0350-PM 13657

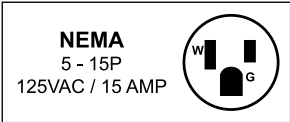
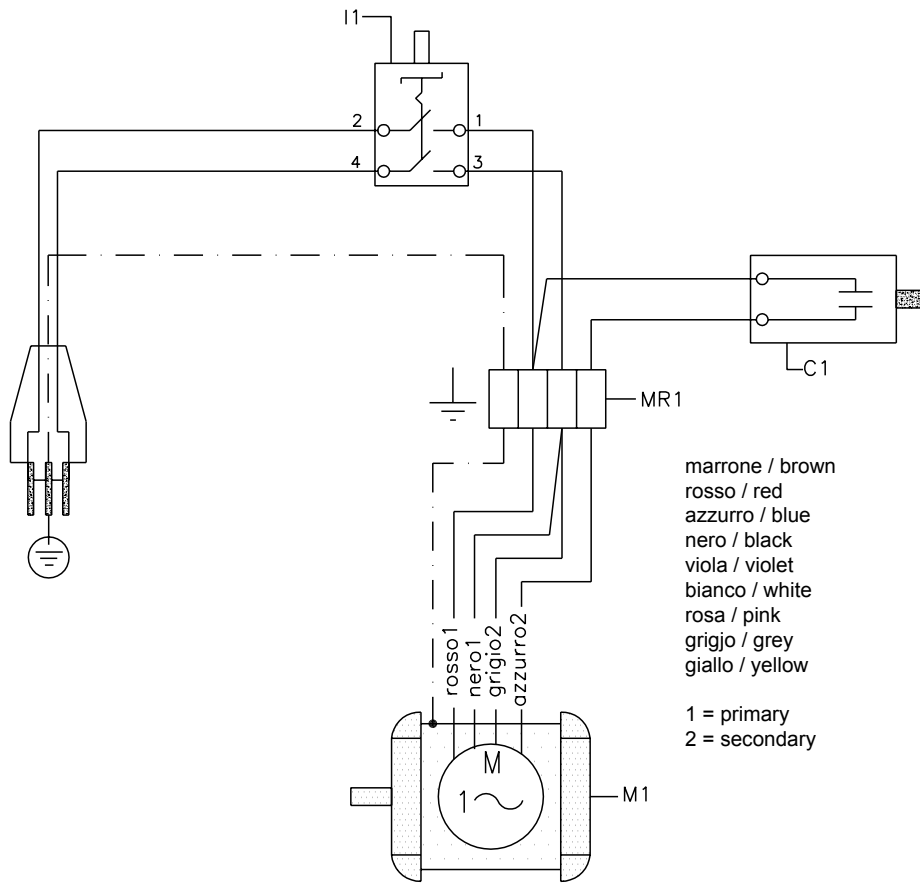

Position	Description
C1	Capacitor 14µF 450V
C1	Capacitor 20µF 450V (C-120V/60Hz)
I1	Switch
MR1	Terminal Board
M1	Motor



Warranty Registration

Thank you for purchasing an Omcan product. To register your warranty for this product, complete the information below, tear off the card at the perforation and then send to the address specified below. You can also register online by visiting:

Merci d'avoir acheté un produit Omcan. Pour enregistrer votre garantie pour ce produit, complétez les informations ci-dessous, détachez la carte au niveau de la perforation, puis l'envoyer à l'adresse spécifiée ci-dessous. Vous pouvez également vous inscrire en ligne en visitant:

Gracias por comprar un producto Omcan usted. Para registrar su garantía para este producto, complete la información a continuación, cortar la tarjeta en la perforación y luego enviarlo a la dirección indicada a continuación. También puede registrarse en línea en:

<https://omcan.com/warranty-registration/>

For mailing in Canada

Pour postale au Canada

Por correo en Canadá

OMCAN

PRODUCT WARRANTY REGISTRATION

3115 Pepper Mill Court,

Mississauga, Ontario

Canada, L5L 4X5

For mailing in the US

Pour diffusion aux États-Unis

Por correo en los EE.UU.

OMCAN

PRODUCT WARRANTY REGISTRATION

4450 Witmer Industrial Estates, Unit 4,

Niagara Falls, New York

USA, 14305

or email to: service@omcan.com



Purchaser's Information

Name: _____

Address: _____

City: _____ Province or State: _____ Postal or Zip: _____

Country: _____

Dealer from which Purchased: _____

Dealer City: _____ Dealer Province or State: _____

Invoice: _____

Model Name: _____ Model Number: _____

Machine Description: _____

Date of Purchase (MM/DD/YYYY): _____

Would you like to extend the warranty? Yes No

Company Name: _____

Telephone: _____

Email Address: _____

Type of Company:

Restaurant Bakery Deli

Butcher Supermarket Caterer

Institution (*specify*): _____

Other (*specify*): _____

Serial Number: _____

Date of Installation (MM/DD/YYYY): _____

Thank you for choosing Omcan | Merci d'avoir choisi Omcan | Gracias por elegir Omcan



Since 1951 Omcan has grown to become a leading distributor of equipment and supplies to the North American food service industry. Our success over these many years can be attributed to our commitment to strengthen and develop new and existing relationships with our valued customers and manufacturers. Today with partners in North America, Europe, Asia and South America, we continually work to improve and grow the company. We strive to offer customers exceptional value through our qualified local sales and service representatives who provide convenient access to over 6,500 globally sourced products.

Depuis 1951 Omcan a grandi pour devenir un des “leaders” de la distribution des équipements et matériel pour l’industrie des services alimentaires en Amérique du Nord. Notre succès au cours de ces nombreuses années peut être attribué à notre engagement à renforcer et à développer de nouvelles et existantes relations avec nos clients et les fabricants de valeur. Aujourd’hui avec des partenaires en Amérique du Nord, Europe, Asie et Amérique du Sud, nous travaillons continuellement à améliorer et développer l’entreprise. Nous nous efforçons d’offrir à nos clients une valeur exceptionnelle grâce à nos ventes locales qualifiées et des représentants de service qui offrent un accès facile à plus de 6500 produits provenant du monde entier.

Desde 1951 Omcan ha crecido hasta convertirse en un líder en la distribución de equipos y suministros de alimentos en América del Norte industria de servicios. Nuestro éxito en estos años se puede atribuir a nuestro compromiso de fortalecer y desarrollar nuevas relaciones existentes con nuestros valiosos clientes y fabricantes. Hoy con socios de América del Norte, Europa, Asia y América del Sur, que trabajan continuamente para mejorar y crecer la empresa. Nos esforzamos por ofrecer a nuestros clientes valor excepcional a través de nuestro local de ventas y representantes de los servicios que proporcionan un fácil acceso a más de 6,500 productos con origen a nivel mundial.

